

Features:



- ◆ Frequency Range: 5 to 1250 MHz
- ◆ Surface mount and available in tape and reel
- ◆ 260°C reflow compatible
- ◆ RoHS Compliant and Pb free
- ◆ Operating temperature range: -40°C to +85°C
- ◆ Storage temperature range: -55°C to +100°C



Applications:

- ◆ For Enabling CATV, Full Duplex and Docsis 3.1 applications
- ◆ For broadband and wireless communications

Dimension diagram (Unit:mm) :

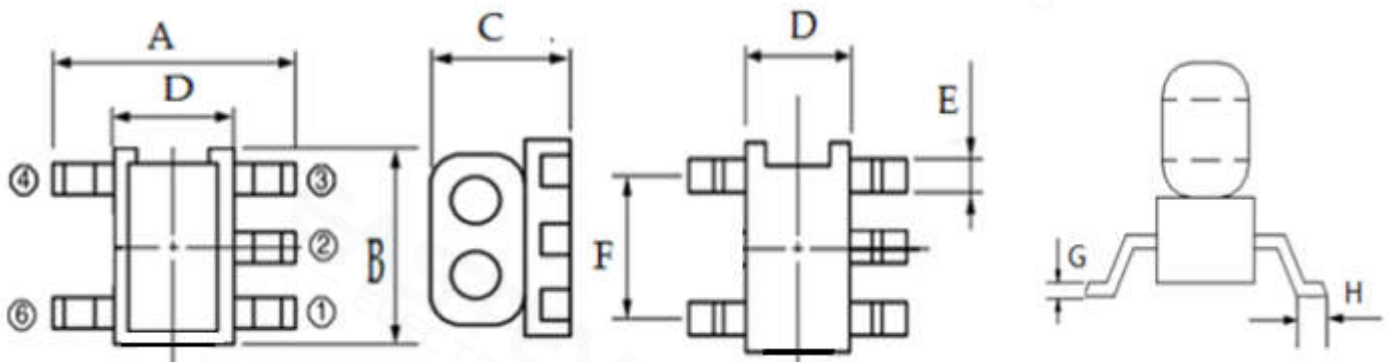

A=5.10±0.20 B=4.30±0.20 C=3.50Max D=2.60±0.20 E=0.50±0.05 F=3.00±0.10 G=0.25±0.05 H=0.60±0.10

Electrical structure:

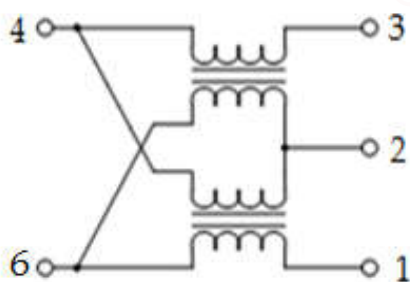

Recommended layout(mm):

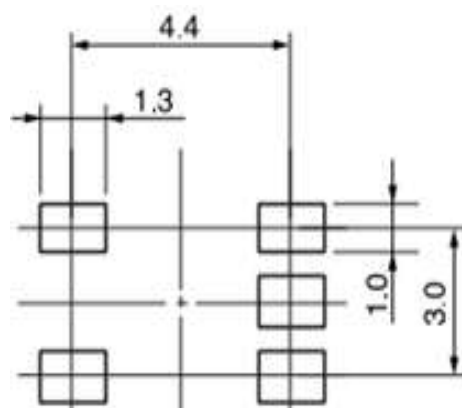

Pin configuration:

Pin no.	Function
1	Input
2	Ground
3	Coupled
4	Terminated
6	Output

Application circuit :

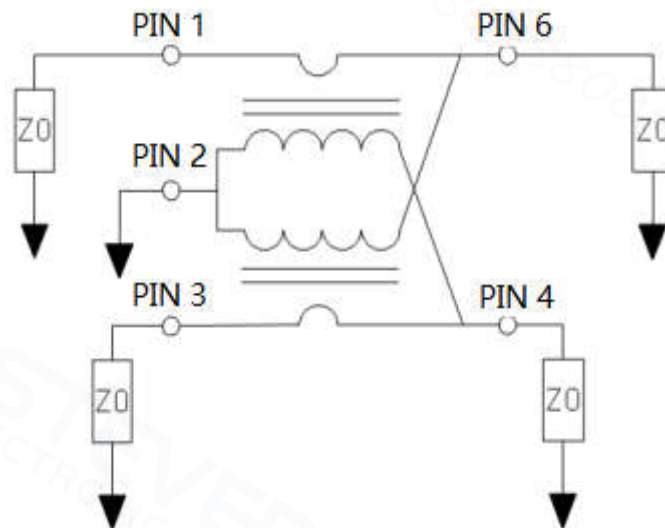

Electrical Specifications: TA=25°C, 0dBm, Z0=75Ω

Parameter	Test Conditions	Units	Min	Typ	Max
Main line Loss	5-1250MHz	dB	-	1.2	1.8
Coupling	5-1250MHz	dB	14.3	14.8	15.7
Input Return Loss	5-1250MHz	dB	16.0	20.0	-
Output Return Loss	5-1250MHz	dB	16.0	22.0	-
Coupling Return Loss	5-1250MHz	dB	16.0	25.0	-
Isolation	5-1250MHz	dB	20.0	25.0	-

Main line Loss(pin1-6):

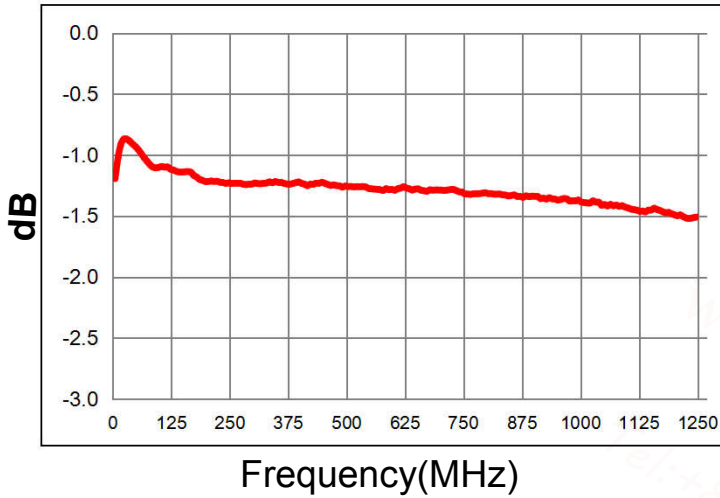

Coupling(pin1-3):

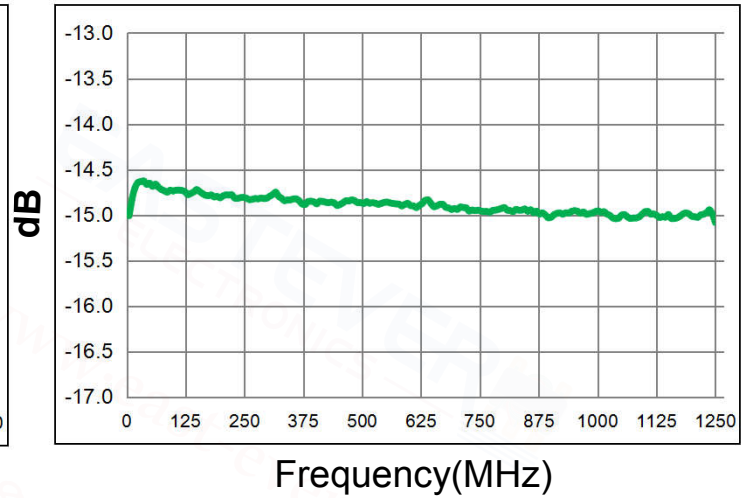

Input Return Loss (Pin1)

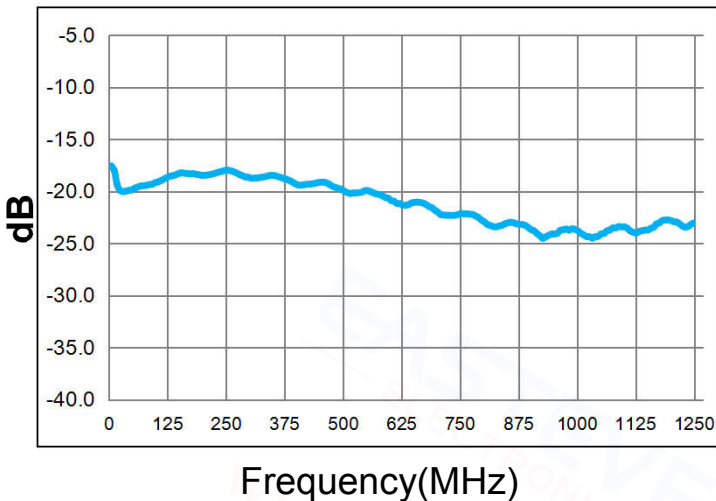

Output Return Loss (Pin6)

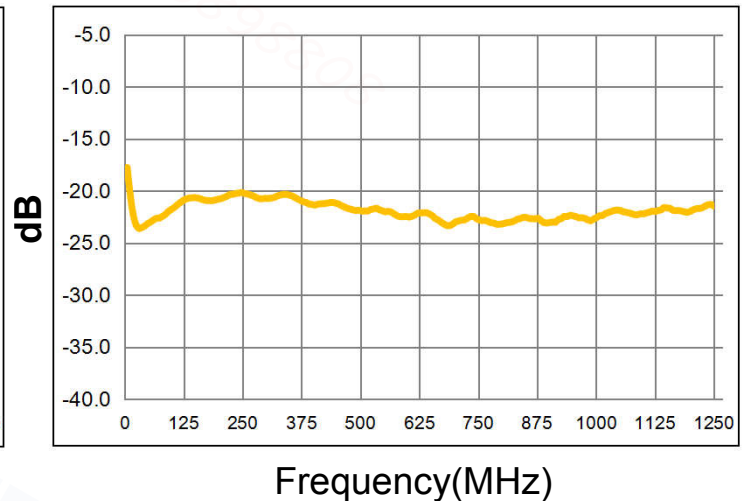

Coupling Return Loss (Pin3)

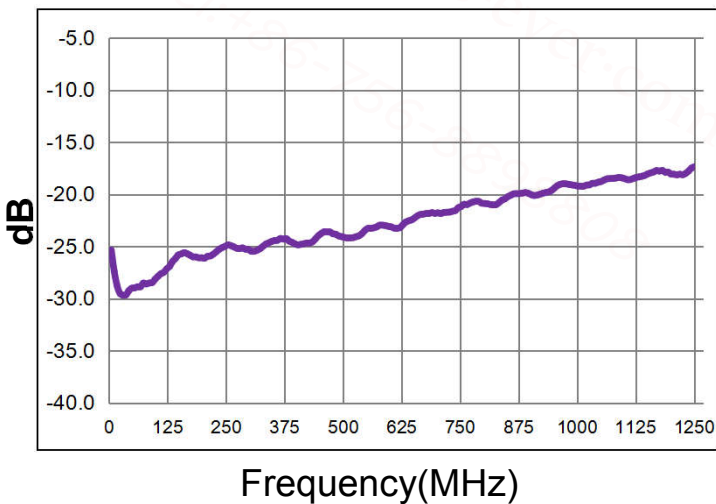

Isolation (Pin3-6)

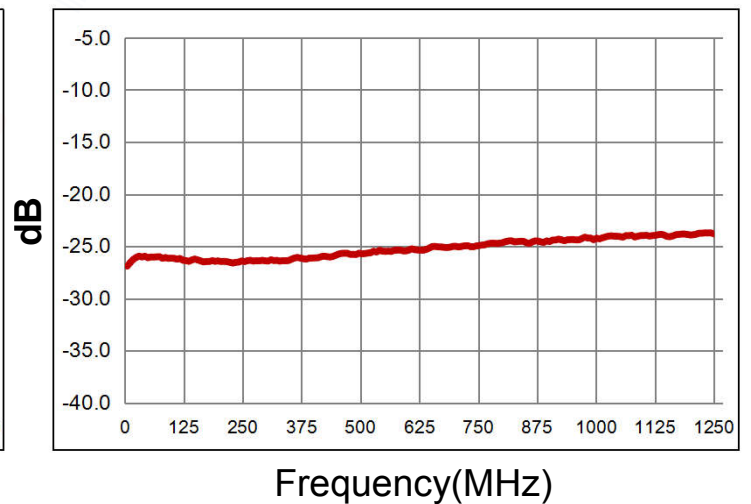

Recommended Soldering Temperature Graph:

Typical RoHS Reflow Profile

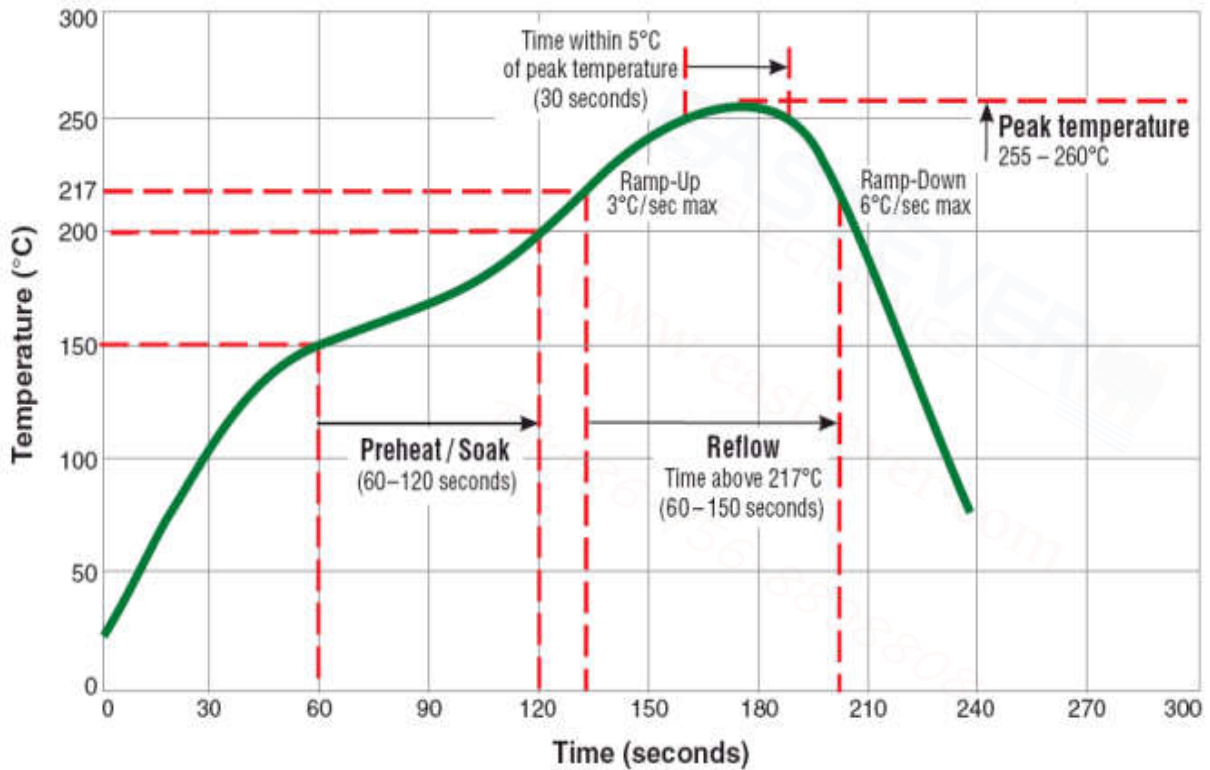

Packaging Dimension For Caeier Tape(UNIT:mm):

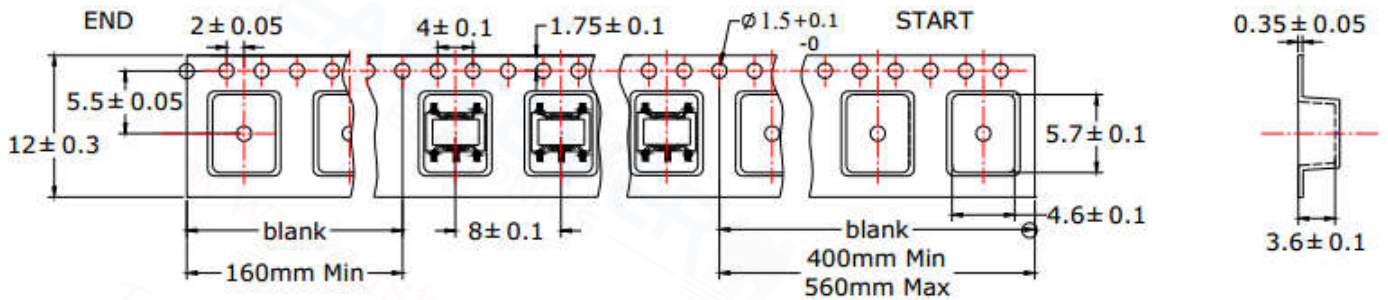

QUANTITY
2000PCS/Reel
4 Reels/Middle Carton Middle Carton:
4 Middle Cartons/Big Carton
32000PCS/ Big Carton

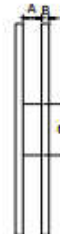
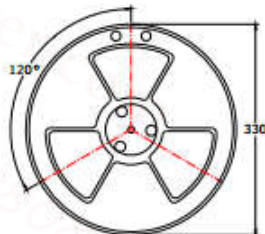

SPEC	8	12	16	24
DIM A±0.1	8.5	12.5	16.5	24.5
DIM B±0.1	2.3	2.3	2.3	2.3
DIM C±0.1	100	100	100	100

