

# Rod Choke Inductor

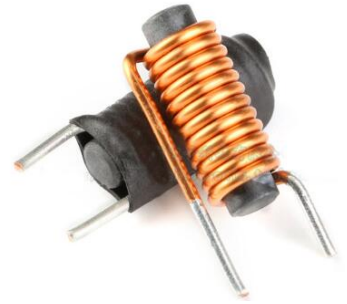

## 1 外形尺寸 Appearance and dimensions (mm)

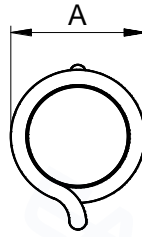
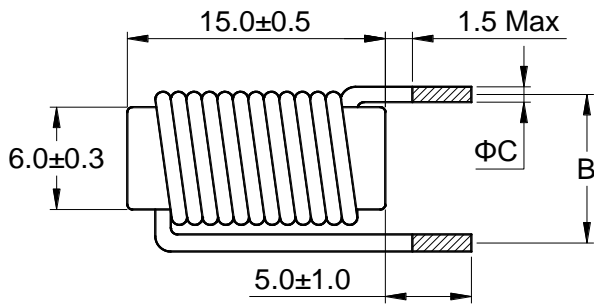

## 2 参考焊孔尺寸 Reference hole pattern (mm)

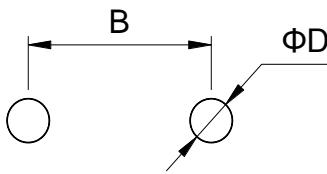

Part No. 型号	A	B	C	D
	Max	±1.0	±0.15	Ref.
1R0	9.60	11.5	1.50	1.90
1R8	8.80	10.0	1.10	1.50
2R2	8.80	10.0	1.10	1.50
3R3	8.50	9.20	0.90	1.30
4R7	8.00	8.50	0.70	1.10
5R0	8.00	8.50	0.70	1.10
6R8	7.80	8.20	0.60	1.00
8R2	7.80	8.20	0.60	1.00
100	7.60	8.00	0.50	0.90
150	7.40	7.50	0.40	0.80
220	7.20	7.00	0.30	0.60

## 3 电气特性 Electrical characteristics

Part No. 品名	Inductance (μH) 电感值 ※1 ±20%	D.C.R. (mΩ) 直流电阻		Saturation current (A) 饱和电流 ※2	Temperature rise current (A) 温升电流 ※3
		Typical	Max	Typical	Typical
KRA0615-1R0M	1.00	1.71	2.23	24.0	31.5
KRA0615-1R8M	1.80	3.85	5.00	23.0	21.0
KRA0615-2R2M	2.20	5.30	6.90	21.0	17.9
KRA0615-3R3M	3.30	8.40	10.9	19.0	14.2
KRA0615-4R7M	4.70	16.4	21.3	15.5	10.2
KRA0615-5R0M	5.00	17.2	22.4	15.0	9.90
KRA0615-6R8M	6.80	24.8	32.2	14.0	8.30
KRA0615-8R2M	8.20	30.6	39.8	12.5	7.45
KRA0615-100M	10.0	46.0	59.8	11.0	6.00
KRA0615-150M	15.0	84.0	109	9.00	4.50
KRA0615-220M	22.0	134	174	7.50	3.55

■ All data is tested based on 25°C ambient temperature.

所有数据基于环境温度 25°C 条件下测试。

※1 Inductance measure condition at 1kHz, 0.25V.

电感测试条件为 1kHz, 0.25V。

※2 Saturation current: the actual value of DC current when the inductance decrease 20% of its initial value.

饱和电流: 电感值下降其初始值的 20% 时所加载的实际直流电流值。

※3 Temperature rise current: the actual value of DC current when the temperature rise is ΔT40°C (Ta=25°C).

温升电流: 使产品温度上升到 ΔT40°C 时所加载的实际直流电流值 (Ta=25°C)。

※ Special remind: Circuit design, component placement, PWB size and thickness, cooling system and etc. all will affect the product temperature. Please verify the product temperature in the final application.

特别提醒: 线路设计, 组件布局, 印刷线路板(PWB)尺寸及厚度, 散热系统等均会影响产品温度。

请务必在最终应用时, 验证产品发热状况。



Balun Transformer | Coupler | Divider | Inductor | Choke | Bead Air Coil | LAN Transformer