

LAN Transformer



100/1000 BASE-T SG48008-3PG

ÜÖX10

A. MECHANICAL(unit:mm)

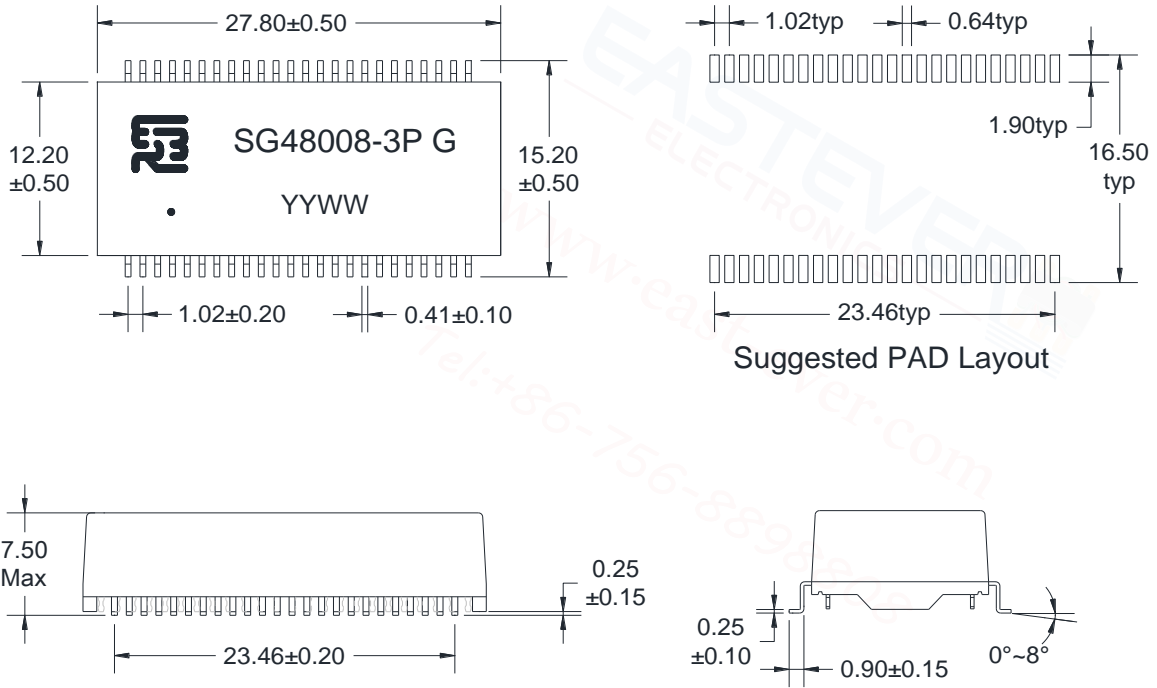

B. SCHEMATICS

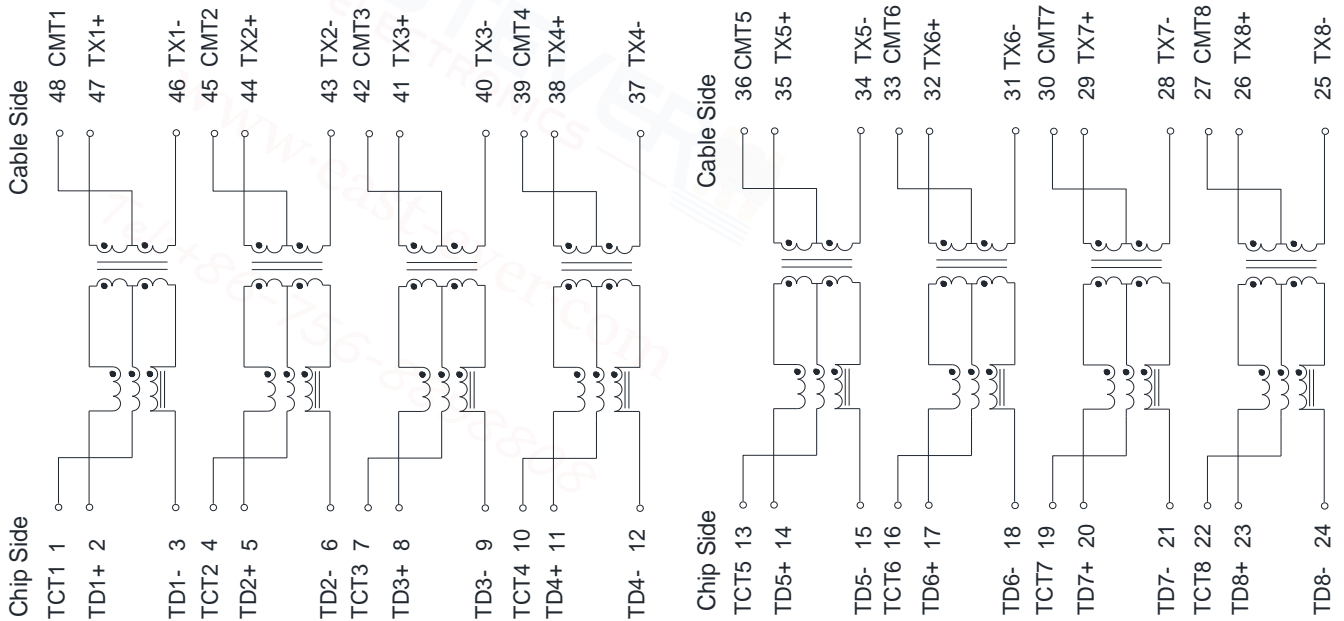

Balun Transformer | Coupler | Divider | Inductor | Choke | 9\X | Air Coil | LAN Transformer

Zuhai Eastever Electronic Co.,Ltd | No.265 Chang Ping Road,GongBei ,ZhuHai,China | www.east-ever.com | james@yfbalun.com | Tel:" 86-756-8898808

C. ELECTRICAL SPECIFICATIONS @25°C

1. OCL: 350uH Min @ 100 KHz, 0.1V with 8mA DC BIAS
2. Leakage Inductance: 0.5uH Max @ 100KHz, 0.1V
3. DCR: 1.4 Ω Max
4. Turns Ratio: 1CT:1CT±5%
5. Insertion Loss: -1.2 dB Max @ 0.5-1 MHz
-0.2-0.002*f^{1.4} dB Max @ 1-125 MHz
6. Return Loss: -16 dB Min @ 1-40 MHz
-10+20*log (f/80) dB Min @ 40.1-100 MHz
7. Cross Talk: -30 dB Min @ 1-100 MHz
8. Common Mode Rejection: -30 dB Min @ 1-100 MHz
9. Isolation Hipot: 1500VAC 1mA 60S
10. Operating temperature -40°C to +85°C
11. Storage temperature -40°C to +125°C
12. 720mA Current Capability--It is suitable for IEEE 802.3at

D. PAGE INFORMATION

Package Quantity:

One Reel=350Pcs

One Inner Carton=350*2=700Pcs

One Export Carton=700*2=1400Pcs

